

## Automatic Door Bottoms - Surface

All products this page



- Mounts on push side of door.
- Use with a threshold for maximum sealing capability.
- Nylon brush recommended for carpet applications where no threshold is provided.
- Specify exact net length required to avoid field sizing.
- 36" and longer may be cut up to 4" in the field, under 36" should not be cut in the field, order net length.
- Minimum length 11", maximum length 60" (except 780).
- End caps furnished standard. Models 220, 221, 229, 310 require door handing, RH supplied standard.

silicone is gray  
neoprene is black  
brush is gray with mill finish  
and stainless steel; black with  
gold, DKB and brass

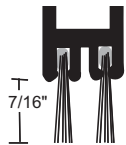

Drop Bar with Nylon Brush - suffix "WH"

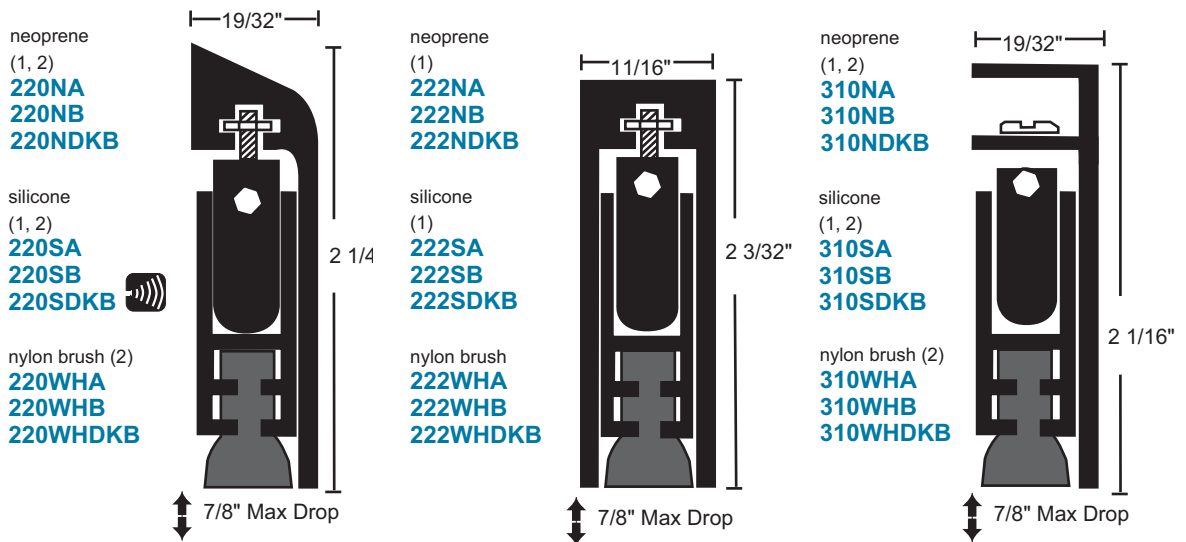

## Slimline

Endurance Tested to 5 Million Cycles

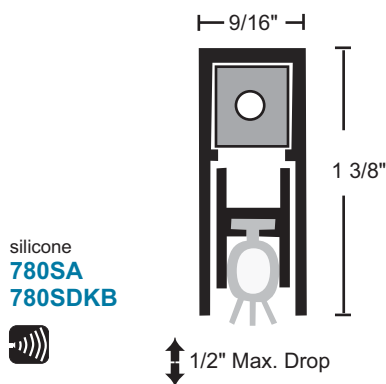

Available 23" to 96" in length  
End caps furnished standard.  
Will work half mortised on swing or sliding doors!

## Brass and Stainless Steel

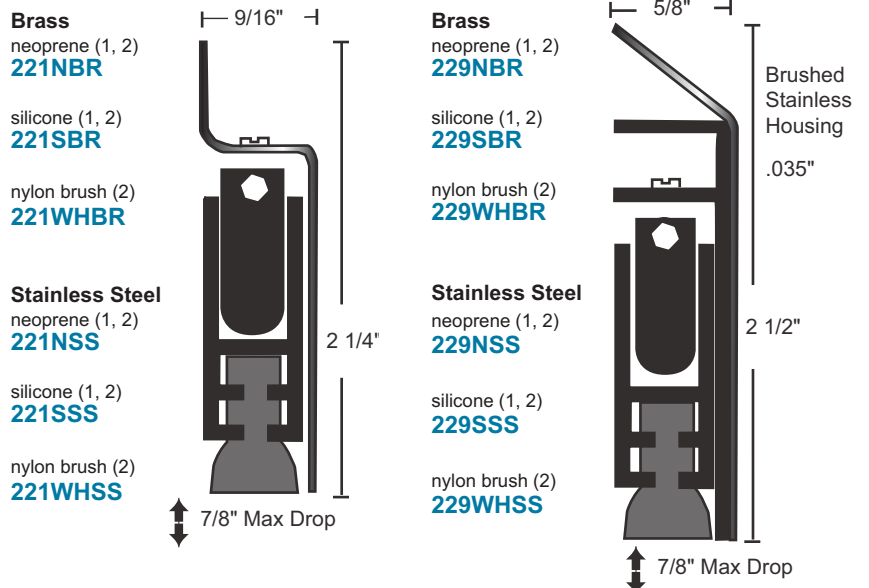

1. Lead insert available for radiation shield - specify "lead-lined"
2. Door Bottom is handed. Right hand supplied unless specified. Field reversible.