

NFPA 80, Section 3-3.8 requires intermediate pivot on some fire door applications, consult factory. Use for door heights over 7'0" and one every 2'6" or . Use for door weight over the pivot set limit. One additional for every additional 100 pounds. Door thickness 1-3/4" minimum with 1/8" bevel in 2".

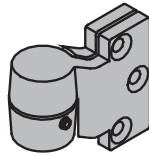

Meets ANSI/BHMA A156.4 C07382

7212-7212V-7222 INT

- Use with 7212, 7212V or 7222 3/4 Offset Pivot
- Handed
- Vertical adjustment 3/16", include positive locking.

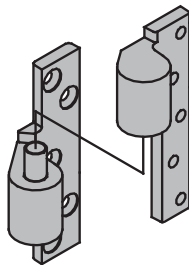
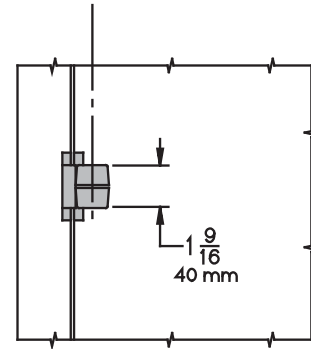
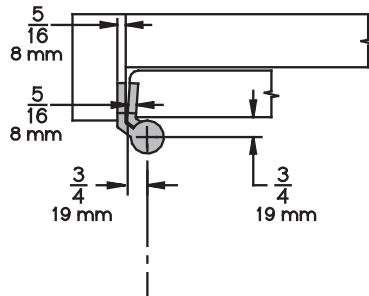
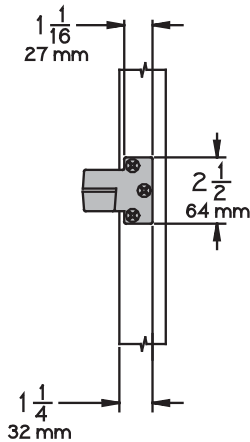

7215-7226-7227 INT:
UL listed 20 minute fire doors
Meets ANSI/BHMA A156.4 C07321

7215-7226-7227 INT

- Use with 7215, 7226 or 7227 3/4 Offset Pivot
- Handed
- Vertical adjustment 3/16", include positive locking.

7215F-7226F-7227F INT:
UL listed 3 hour fire doors
Meets ANSI/BHMA A156.4 C07371

7215F-7226F-7227F INT

- Use with 7215F, 7226F or 7227F 3/4 Offset Pivot
- Handed
- Vertical adjustment 3/16", include positive locking.

